



Contents lists available at ScienceDirect

Journal of the Mechanical Behavior of Biomedical Materials

journal homepage: <http://www.elsevier.com/locate/jmbbm>

## A new design of a multifunctional abutment to morse taper implant connection: Experimental mechanical analysis

Sergio Alexandre Gehrke<sup>a,b,\*</sup>, Berenice Anina Dedavid<sup>c</sup>,  
Gustavo Vicentis de Oliveira Fernandes<sup>d</sup>

<sup>a</sup> Department of Biotechnology, Universidad Católica de Murcia, 30107, Murcia, Spain

<sup>b</sup> Department of Research, Biotecnos - Technology and Science, 11100, Montevideo, Uruguay

<sup>c</sup> Department of Materials Engineering, Pontificia Universidade Católica do Rio Grande do Sul, 90619-900, Porto Alegre, Brazil

<sup>d</sup> Faculty of Dental Medicine at Universidade Católica Portuguesa, Viseu, Portugal, Center for Interdisciplinary Research in Health (CIIS), Institute of Health Sciences, Universidade Católica Portuguesa, 3504-505, Viseu, Portugal

### ARTICLE INFO

#### Keywords:

Abutment design  
Dental implants  
Mechanical cycling  
Morse taper connection  
Screw detorque  
Tensile strength

### ABSTRACT

The objective of this study was to evaluate a new design of multifunctional abutment for Morse taper implant connections, relative to the retentive stability after the application of cyclic loads in cemented and screwed crowns. Multifunctional abutments with two different angulations in the seating portion of the crown were tested, forming 2 groups (n = 30 samples per group): Group Abut11, where Smart abutments with an angle of 11.42° were used; Group Abut5, where Ideale abutments with an angle of 5° were used. Fifteen samples from each group received cemented crowns (CC) and another fifteen screwed crowns (SC). All crown samples were subjected to the mechanical cycling test at 360,000 cycles at a frequency of 4 Hz and 150 N of the load. The samples with CC were subjected to the tensile test to remove the crowns, while in the samples with SC, the detorque value of the fastening crown screws was measured. The mean tensile strength value of CC in the Abut11 group was 131.9 ± 13.5 N and, in the Abut5 group was 230.9 ± 11.3 N; while the detorque mean value in samples with SC 5.8 ± 1.8 N for the Abut11 group and, 7.6 ± 1.1 N for Abut5 group. Significant statistical differences were found between the two groups in both situations tested (p < 0.05). The multifunctional abutments, presenting a lesser angulation of the crown-seating portion, showed higher values of retention of the CC and a lesser screw loosening of torque of the fixing screws in the SC after the application of cyclic loads when compared to the abutments with more angulation in the crown-seating portion.

### 1. Introduction

After denta implant osseointegration, the major concern in oral rehabilitation treatments is the long-term mechanical stability. Mechanical failures can generate complications at different levels, which are easy to solve or, conversely, to the extreme, which may lead to osseointegration loss. In this sense, the first point to be observed is the adaptation degree between the implant-abutment interface (IAI), which is directly related to the precision in the components manufactured and to the torque applied to the abutment screws (Gehrke et al., 2016a,b; Kano et al., 2007). Thus, the nature of the loosening and fracture of the components are complex and involves precision in adapting the IAI, cyclic fatigue, oral fluids' presence, chewing pattern, and load (Huang

and Wang, 2019; Kitagawa et al., 2005). Inadequate adaptation of the interface has been considered the primary cause of tension loss of the screws. Some studies carried out previously (Ribeiro et al., 2011), have shown an imprecise interface provides excessive stress on the abutment screw, which can generate mechanical failures.

The stability of the prosthetic connection and the tendency to loosen the abutments can be influenced by the type of prosthetic connection selected, and the Morse taper connection has shown better results when compared to hexagonal connections (Gehrke et al., 2017; Jorge et al., 2013). However, there are variations between the models of conical connections that can present different results regarding the mechanical stability during the application of cyclic loads (Scarano et al., 2015, 2016; Jorge et al., 2013; Ozdiler et al., 2018).

\* Corresponding author. Biotecnos - Technology and Science; Calle Cuareim, 1483, 11.100 - Montevideo, Uruguay.

E-mail addresses: [sgehrke@ucam.edu](mailto:sgehrke@ucam.edu), [sergio.gehrke@hotmail.com](mailto:sergio.gehrke@hotmail.com) (S.A. Gehrke), [berenice@pucrs.br](mailto:berenice@pucrs.br) (B.A. Dedavid), [gustfernandes@gmail.com](mailto:gustfernandes@gmail.com) (G.V. de Oliveira Fernandes).

<https://doi.org/10.1016/j.jmbbm.2021.104347>

Received 13 November 2020; Received in revised form 13 January 2021; Accepted 16 January 2021

Available online 22 January 2021

1751-6161/© 2021 The Authors. Published by Elsevier Ltd. This is an open access article under the CC BY license (<http://creativecommons.org/licenses/by/4.0/>).

As for the type of rehabilitation currently used, there are two retention-types, cemented and screwed crown, each of which has some peculiar advantages and disadvantages. Several factors are related to the different methods of retaining the prosthesis to the implants: ease of manufacture and cost, esthetics, access, occlusion, retention, the incidence of retention loss, recovery capacity, the passivity of the adjustment, restriction of the implant position, the effect on the health of peri-implant tissues, provisionalization, immediate loading, printing procedures, porcelain fracture, and clinical performance (Shadid and Sadaqa, 2012). However, there is no consensus on which is the ideal model to be used for prosthetic rehabilitation. In daily practice, it is known that cemented prostheses are more similar to conventional crowns and, that screwed crown facilitates work for professionals.

Retention safety is considered one of the most important factors that affect the longevity of implant prostheses (Assaf and Gharbyeh, 2014; Shadid and Sadaqa, 2012). Several factors affect the retention of restorations retained by cement, such as the abutment-taper, the area and height of the surface, the surface roughness, and cement-type (Almehmadi et al., 2019; Jorgensen, 1955; Lövgren et al., 2017; Saleh Saber et al., 2012). Moreover, the angulation of the abutment walls greatly affects the amount of retention for that cemented crowns (Tan et al., 2012), with the most machined abutments having 6 degrees of angulation, following the concept of ideal taper proposed for natural teeth (Jorgensen, 1955). Regarding the area and height of the cementation surface of the abutments, the subgingival placement of the implants provides longer walls of the implant abutment and generally more surface area than the prepared natural teeth (Shadid and Sadaqa, 2012; Wittneben et al., 2017). However, the minimum abutment height for the use of cemented restorations with safe retention has been reported at 5 mm (Shadid and Sadaqa, 2012).

Recently, new multifunctional abutments have been developed to facilitate prosthetic rehabilitation on Morse taper implant connections, which allow the crown to be screwed or cemented. A modification in the initial design of the Smart multifunctional abutment was the decrease in the taper presented in the seating portion of the crown, originating the Ideale abutments. Thus, this present study aimed to compare the new Ideale abutments with the Smart abutments for Morse taper implants, evaluating the behavior after receiving cyclic loads in CC and SC crowns. In addition, the resistance to the removal of CC and the detorque values of the screws fixing the SC were also analyzed. The null hypothesis was that the reduction of the abutment angulation did not provide more retention in the unit cemented crowns or more maintaining the torque of the screws in screwed crowns.

## 2. Materials and methods

### 2.1. Materials

Straight multifunctional abutments with two different angles were used in the seating portion of the crown, forming 2 groups ( $n = 30$  samples per group): Group Abut11, where Smart abutments with an angle of  $11.42^\circ$  were used; Group Abut5, where Ideale abutments with an angle of  $5^\circ$  were used. Both abutments were produced for Morse taper connection implants. All abutments of both groups were manufactured in titanium F67 grade IV, and the abutments of the Abut5 group were anodized after the machining. The mean value of roughness (Sa) provided by the manufacturer for the abutments of the Abut5 group was  $2.212 \pm 0.265 \mu\text{m}$  and, for the Abut11 group, it was  $2.176 \pm 0.246 \mu\text{m}$ . The dimensional characteristics of both columns are shown in Fig. 1. A total of 60 sets (plastic castable copings, implants, and abutments) were used, which are presented in Fig. 2. The implants used were tapered and had dimensions of 4 mm in diameter and 13 mm in length. All materials (abutments and implants) used are manufactured and marketed by the company Implacil De Bortoli (São Paulo, Brazil). Fifteen samples from each group received cemented crowns (CC) and another fifteen screwed crowns (SC).

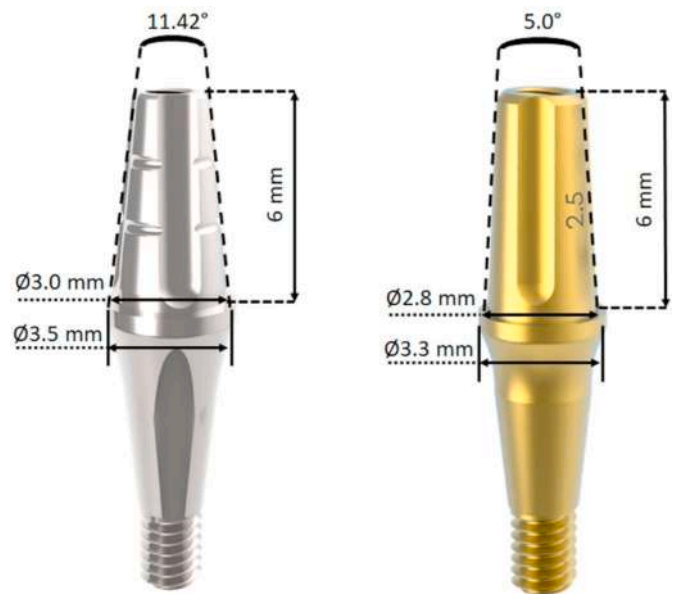

Fig. 1. Dimensional characteristics of the Smart abutment (left) and Ideale abutment (right).

The sample size was based on a power level of 85% to obtain a P value of 0.05, calculated by using a software program (SigmaStat 4.0; Systat Software Inc). For a desired power level of 85% with differences between the means and standard deviations of each group, the minimum sample size for each group under each condition was 12 sets (implant and abutment).

### 2.2. Crown elaboration

Sixty metallic crowns were made using the prefabricated calcined plastic copings, these metallic crowns in semicircular shape in a nickel-chromium alloy (Fit Cast Titanium, Talmax, Paraná, Brazil), fifteen crowns for cementation at each abutment ( $n = 30$ ) and fifteen crowns for screwing at each abutment ( $n = 30$ ). All cast crowns presented internally the engage to the abutment keyway, thus being anti-rotational crowns. To facilitate the tensile test (crown removal), a transverse perforation was made at the top of each crown for cementation. Fig. 3 shows the schematic drawing prepared for each type of crown (CC and SC). After casting, each crown was blasted internally with aluminum oxide (granulation  $60\text{--}80 \mu\text{m}$ ) to remove the coating and machined with finishing stones and polishing rubbers on the entire external surface. These internal and external cleaning procedures to remove coating residues are the same as those used during the manufacture of conventional metal-ceramic crowns and, do not aim to produce abrasion. The verification of the adaptation of each crown was performed by visual inspection simulating the laboratory and clinical procedure. The final length of the abutment and crown set from the implant platform was 11 mm for both crown models (CC and SC) for both groups.

### 2.3. Sample preparation for testing

Initially, sixty DuoCone Morse taper implants ( $\text{Ø}4.0 \text{ mm} \times 13 \text{ mm}$  long) were included in a rigid epoxy resin (G4, Polipox, São Paulo, Brazil) at an angle of  $30 \pm 2^\circ$ , following the standard ISO 14801:2015 (International Organization for Standardization, 2015), shown in Fig. 4. In each implant, one abutment of each group with the dimensions previously described was installed and torqued (30 Ncm).

The cementation of the crowns to the abutments was performed with zinc phosphate cement (SS White, Rio de Janeiro, Brazil), following the manufacturer's recommendations to the manipulation, being applied

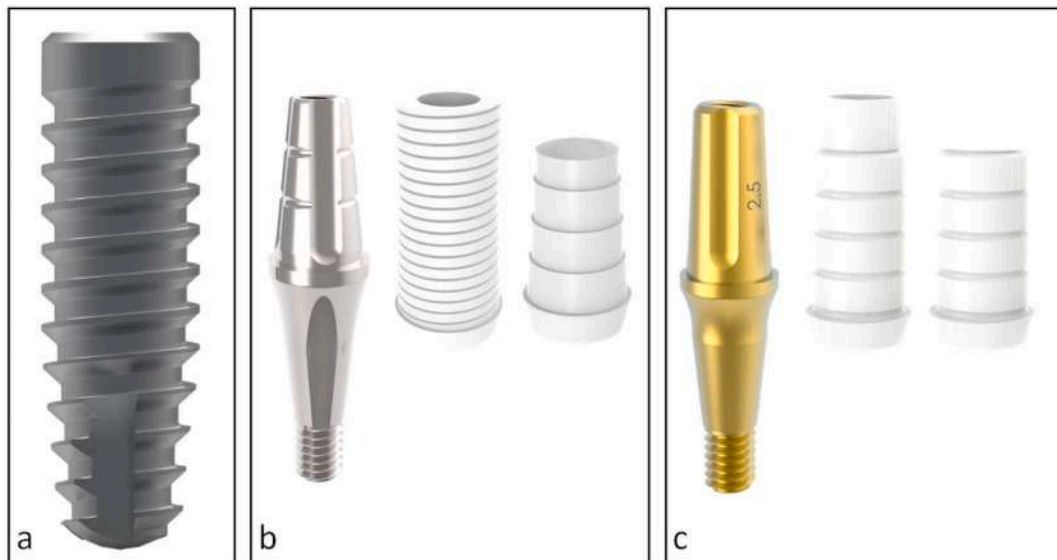

Fig. 2. (a) Tapered implant used in the study; (b) Smart abutment and plastic copings for CC and SC – Abut11 group; (c) Ideale abutment and plastic copings for CC and SC – Abut5 group.

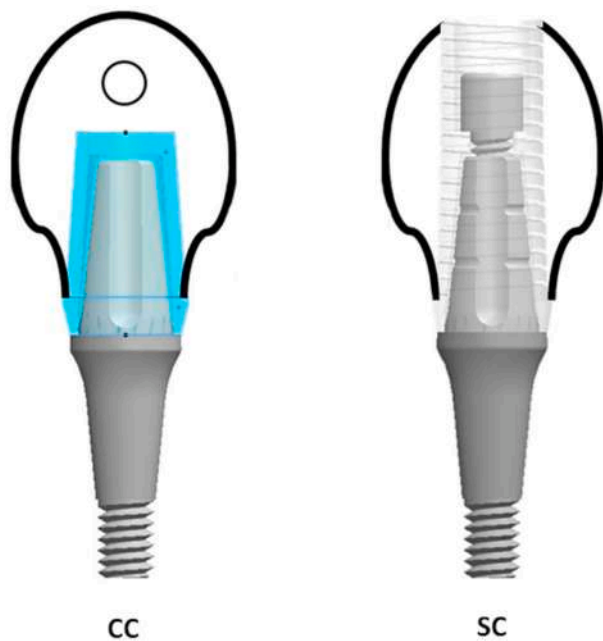

Fig. 3. Schematic drawing for cemented crown (CC) and screwed crown (SC).

uniformly inside the crowns with the aid of a probe. During the cementation, on each crown was applied a constant load of 6 Kgf for 5 min (Breeding et al., 1993), using a load cell (Industrial Técnica Oswaldo Filizola Ltda, São Paulo, Brazil), remaining after that period in the water at  $37 \pm 2^\circ\text{C}$  until the test is carried out. For the maintenance of temperature and water circulation, a thermoregulatory device model Biocycle V2 (BioPDI, São Carlos, Brazil) was used. The screwed crowns received a manual torque of 10 Ncm, as recommended by the manufacturer. All screws were retorqued at 10 min after the first torque (Breeding et al., 1993).

#### 2.4. Mechanical cycling

All samples were subjected to the cyclic fatigue test on the Biocycle V2 mechanical machine (BioPDI, São Carlos, Brazil), receiving an

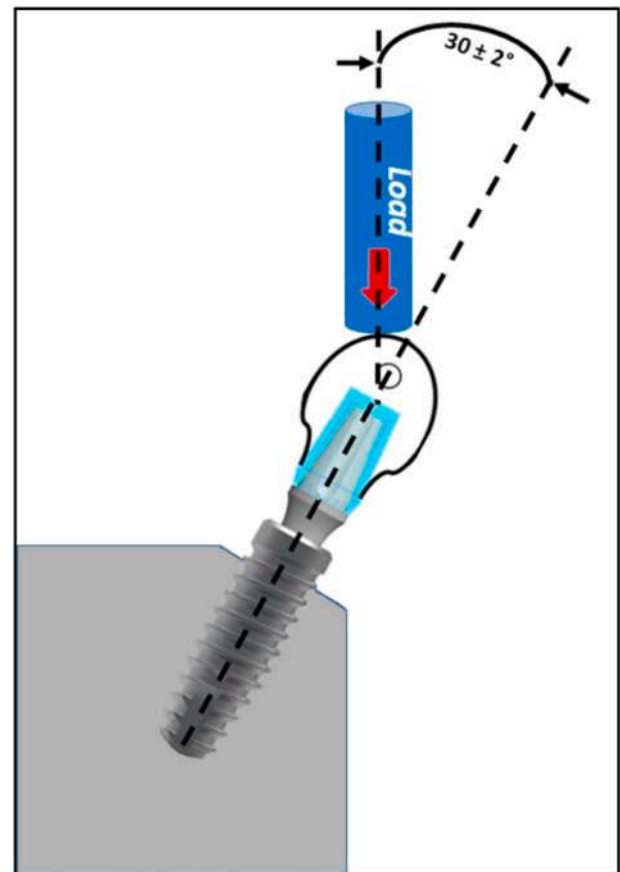

Fig. 4. Illustrative image of the cycling load application on the samples.

application of 360,000 cycles with a controlled non-axial force of 150 N at 4 Hz of frequency, following the standards (load applied, number of cycles, and frequency) of previous studies published (Gehrke et al., 2016, 2017). During the mechanical cycle, the samples were immersed in water at a controlled temperature of  $37 \pm 2^\circ\text{C}$ . After the application of cyclic fatigue, all samples were dried to perform the proposed tests.

## 2.5. Crown removal and detorque measurements

The tensile test (crowns removal) was performed using the universal machine AME-5kN (Industrial Técnica Oswaldo Filizola Ltda, São Paulo, Brazil) with a speed of 3 mm/min, with a displacement measurement system with a resolution of 0.001 mm. The maximum values of traction were measured and recorded for both groups. For the detorque measurements, it was used as a computerized torque testing machine CME-30nm (Técnica Industrial Oswaldo Filizola, São Paulo, Brazil). The thirty screws ( $n = 15$  per group) of the crowns were detorqued, and the maximum value was measured in each sample.

## 2.6. Statistical analysis

Statistical analyses were performed using the *t*-test to determine the differences between the groups in both crown design (CC and SC). The analysis used  $p < 0.05$  to determine statistical significance. GraphPad Prism program, version 5.01 (GraphPad Software), was used to perform all statistical analyzes.

## 3. Results

During the fatigue test, none of the crowns detached from the abutment and/or showed mobility. All samples showed an adequate stability between the crown and abutment after the end of the mechanical cycling (Fig. 5).

In the analysis of cemented crowns for the two abutment models tested, the Abut5 group showed higher tensile values (average 75% more) than the values obtained in the samples of the Abut11 group ( $p < 0.0001$ ). While in the analysis of the screws detorque, the Abut5 group presented values on average 31% higher than the samples of the Abut11 group ( $p = 0.0086$ ). Table 1 shows data of both groups for both crown-models tested. Fig. 6 shows the data obtained in both groups graphically for the two types of crowns tested (CC and SC).

## 4. Discussion

Currently, osseointegrated dental implants have achieved a high success rate, with levels greater than 95% (Moraschini et al., 2015). However, adverse results are directed to prosthetic rehabilitation due to the occurrence of mechanical complications, such as crown loosening and fracture of screws (Chitumalla et al., 2018; Gupta et al., 2015). Within this scene, therefore, there is still no consensus about the better system of crown fixation to reduce the aforementioned problems, whether by cementation or screwing, which can present advantages and disadvantages, leading professionals' choice after to analyze the best option to proceed with the treatment. Our study compared two models of abutments that can be used both in cemented and screwed crowns, with respect to maintaining the stability of these crowns when in function, which has as the main difference between them the angle of the crown seating portion in the abutment. The results showed that

**Table 1**

Means, standard deviation, median, and confidence interval variation of the measured values obtained in the fatigue test, for both groups, for Cemented crowns (values in N) and Screwed crowns (values in Ncm).

Groups	Cemented crowns			Screwed crowns		
	Mean $\pm$ SD	Median	95% CI	Mean $\pm$ SD	Median	95% CI
Abut11	131.9 $\pm$ 13.5	129.0	124.4 to 139.4	5.8 $\pm$ 1.8	5.5	4.810 to 6.857
Abut5	230.9 $\pm$ 11.3	232.0	224.6 to 237.1	7.6 $\pm$ 1.1	8.0	6.958 to 8.176

SD = Standard deviation; CI = Confidence interval variation.

reduction of the abutment angulation caused a significant increase in the resistance to decementation of the cemented single unit crowns and decrease the torque loss of the screwed single unit crowns after the fatigue cycling. These findings rejected the null hypothesis that the reduction of the abutment angulation did not provide more retention in the unit cemented crowns or more maintaining the torque of the screws in screwed crowns. Other authors have also shown similar results when the abutment design was altered to generate more stability and retention for unit crowns installed on implant abutments (Bernal et al., 2003; Emms et al., 2007; Tan et al., 2012).

On the other hand, many authors agreed the more efficient system for cementation of the unitary crown is found in the Morse taper connection, besides many biological advantages and lower possibility of abutments loosening after chewing function (Caricasulo et al., 2018; Schmitt et al., 2014). Conversely, when observed the characteristic of reversibility, due to crowns removal to adjust ceramic fractures, change color, or to repeat the crown due to other problem, authors affirmed that these aspects must be considered in the treatment planning (Gómez-Polo et al., 2018; Schoenbaum et al., 2018), whereby favor the screwed abutment, even though the tightening torque performed with a manual wrench found variability for the same operator, between different operators, and among implant systems (Al-Otaibi, 2016; Internet Access, 2020; Sameera and Rai, 2020).

Thus, the present study compared two different multifunctional abutments for Morse taper connection, assessing different angles and retention-types (cemented *versus* screwed) to provide mechanical information grounded on specific ISO normative (International Organization for Standardization, 2015), to supply lack of evidence in the literature and to give scientific support for clinicians. Therefore, the main limitation of this *in vitro* study might be considered the load applied in a quasi-static system, without the totality and complexity of chewing movements. Controversially, *in vitro* studies are the only way to simulate clinical situations to analyze the behavior of materials without involving and/or affecting patients.

Then, mimetizing the normal and physiological patients' mastication, which chewing loads can range from 20 to 200 Kgf (Internet Access, 2020), mechanical cycling impulses were applied to compare the abutments with variation in the angulation of 11.42° (Abut11) and 5°

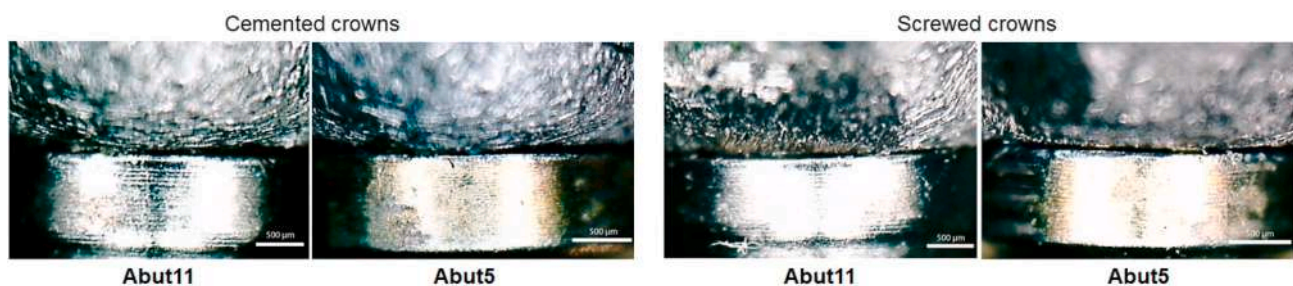

**Fig. 5.** Representative image of a sample for each group after the mechanical cycling test. The first 2 images are CC and the last 2 images are SC, for Abut11 and Abut5 groups, respectively.



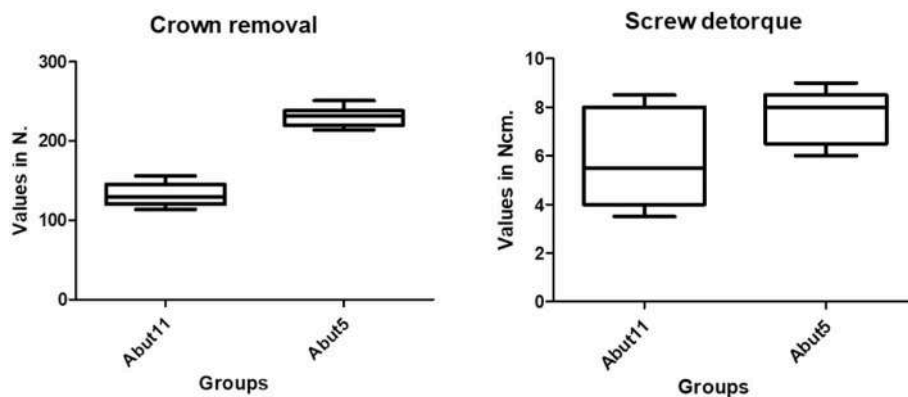

Fig. 6. Graphics of crown removal for cemented samples (Abut11 x Abut5 groups) (left) and screw detorque for screwed samples (Abut11 x Abut5 groups) (right). Crown removal (values in N) and Screw detorque (values in Ncm).

(Abut5), which were evaluated according to crown removal (cemented group) and detorque (screwed crowns). Therefore, there is no consensus in the literature regarding the intensity of load, frequency, and the number of cycles applied to the specimens (Gehrke et al., 2017; Jorge et al., 2013; Moris et al., 2015, 2017). Thus, the present study used the load intensity of 150 N to the samples, with a frequency of 4 Hz and 360,000 cycles, equivalent to 12 months of chewing in a normal individual (Gehrke et al., 2017).

The development of this new abutment for Morse taper connection, amending and reducing the angle to 5° in the cementable portion, aimed to improve the retention and stability of cemented crowns when compared to abutments with greater angle, such as observed in the Abut11 (11.42°). The results obtained in this study showed that the abutment with reduced angle significantly increased the retention of cemented crowns, reaching greater retention of cemented crowns (75% higher) in the new abutments (Abut5 group - Ideale) compared to the abutments of the Abut11 group (Smart). These data corroborate the findings of other authors (Bernal et al., 2003; Bresciano et al., 2005; Moris et al., 2015; Schiessi et al., 2013), who demonstrated the abutment design directly influences the retention of cemented crowns. While comparing the screw-retained crowns, the results showed a less torque loss of the fixing screw (31% less) in the new abutments (Abut5 group - Ideale) compared to the abutments of the Abut11 group (Smart). Possibly the reduction in the abutment's angle increases the contact points between the crown and the abutment, thus decreasing the action of forces on the abutment fixing screw. Moris et al. (2015) also demonstrated a relationship between the abutment diameter and its retention, since smaller diameter abutments had more crown detachment and fracture failures during mechanical cycling than larger diameter abutments (Moris et al., 2017). For this reason, in the present study, the abutments with smaller diameter were selected.

Several studies were already carried out demonstrating the relationship between retention of cemented crowns and the design of the abutment (height, diameter, and angulation) (Bernal et al., 2003; Bresciano et al., 2005; Jorgensen, 1955; Moris et al., 2017; Schiessi et al., 2013; Shadid and Sadaqa, 2012), in which no one had the reduced angulation of 5°. This aspect is important once that the decementation is directly related to the abutment design (angle, diameter, and height) and the type of cement used (Alvarez-Arenal et al., 2016; Safari et al., 2018). The cement-type also is directly involved with the level of retention desired by the professional. Some types of cement, especially resinous, can provide an elevated adhesion between the abutment and the cemented crown, however, the reversibility is compromised. Thus, even with the exposure of the samples to a humid and controlled temperature environment, zinc phosphate cement was chosen because it is a type of cement that provides higher retention than temporary cements, but allows the crown removal if needed (Mehl et al., 2013).

The limitations inherent in this study were: (i) the application of only

morse taper implants; although it was intentional due to the new pillar to be designed specifically for them, beyond the morse has shown better results compared to hexagonal connections (Gehrke et al., 2017). (ii) Moreover, the fatigue test, pursuing to mimetizing the normal and physiological mastication was another limitation, which did not represent the oral movement complexity. (iii) The use of no rotational system during the loading application, which can be a variable that influenced the results. (iv) The design of the crown used in the tests, different from the natural tooth anatomy, to allow a suitable surface for application of off-axis load. (v) In addition, the direction of load application was different from the direction of insertion and removal of the fixing screw. (vi) The last one was the reduced number of materials tested; however, the sample quantity followed the power analysis previously calculated. In addition, future clinical trials are needed to analyze oral behavior according to resistance, retention, and loss of screwed/cementation.

## 5. Conclusions

Within the limitation of this study and based on the results obtained, it was possible to conclude that a decreased angle (from 11.42 to 5°), like existent at the new model of prosthetic abutments (Ideale), caused an augmentation of retention for cemented crowns, with values 75% greater than conventional abutments (Smart), even with cyclical loading application. A similar advantage in the result was observed for the detorque analysis for screwed crowns, favoring also the new abutment with around 31% higher values. Moreover, after compared cemented versus screwed crowns, it was possible to verify more reversible conditions for the screwed group, but more retention in the cemented, suggesting that a minor angle and cemented crown are the best recommendations.

## Author contributions

Sergio Alexandre Gehrke: Conceptualization, data curation, formal analysis, investigation, methodology, writing – original draft, writing – review & editing. Berenice Anina Dedavid: Conceptualization, data curation, writing – original draft, writing – review & editing. Gustavo Vicentis de Oliveira Fernandes: Writing – original draft, writing – review & editing.

## Declaration of competing interest

The authors declare that they have no known competing financial interests or personal relationships that could have appeared to influence the work reported in this paper.

## References

- Almehmedi, N., Kutkut, A., Al-Sabbagh, M., 2019. What is the best available luting agent for implant prosthesis? *Dent. Clin.* 63, 531–545.
- Al-Otaibi, H.N., 2016. Intended and achieved torque of implant abutment's screw using manual wrenches in simulated clinical setting. *J. Contemp. Dent. Pract.* 17, 897–901.
- Alvarez-Arenal, A., Gonzalez-Gonzalez, I., deLlanos-Lanchares, H., Brizuela-Velasco, A., Pines-Hueso, J., Ellakuria-Echebarria, J., 2016. Retention strength after compressive cyclic loading of five luting agents used in implant-supported prostheses. *BioMed Res. Int.* 2016, 2107027.
- Assaf, M., Gharbyeh, A.Z.A., 2014. Screw-retained crown restorations of single implants: a step-by-step clinical guide. *Eur. J. Dermatol.* 8, 563–570.
- Bernal, G., Okamura, M., Muñoz, C.A., 2003. The effects of abutment taper, length and cement type on resistance to dislodgement of cement-retained, implant-supported restorations. *J. Prosthodont.* 12, 111–115.
- Breeding, L.C., Dixon, D.L., Nelson, E.W., Tietge, J.D., 1993. Torque required to loosen single-tooth implant abutment screws before and after simulated function. *Int. J. Prosthodont.* (IJP) 6, 435–439.
- Bresciano, M., Schierano, G., Manzella, C., Screti, A., Bignardi, C., Preti, G., 2005. Retention of luting agents on implant abutments of different height and taper. *Clin. Oral Implants Res.* 16, 594–598.
- Caricasulo, R., Malchiodi, L., Ghensi, P., Fantozzi, G., Cucchi, A., 2018. The influence of implant-abutment connection to peri-implant bone loss: a systematic review and meta-analysis. *Clin. Implant Dent. Relat. Res.* 20, 653–664.
- Chitumalla, R., Halini Kumari, K.V., Mohapatra, A., Parihar, A.S., Anand, K.S., Katragadda, P., 2018. Assessment of survival rate of dental implants in patients with bruxism: a 5-year retrospective study. *Contemp. Clin. Dent.* 9, S278–S282.
- Emms, M., Tredwin, C.J., Setchell, D.J., Moles, D.R., 2007. The effects of abutment wall height, platform size, and screw access channel filling method on resistance to dislodgement of cement-retained, implant-supported restorations. *J. Prosthodont.* 16, 3–9.
- Gehrke, S.A., Delgado-Ruiz, R.A., Prados Frutos, J.C., Prados-Privado, M., Dedavid, B.A., Granero Marín, J.M., Calvo Guirado, J.L., 2017. Misfit of three different implant-abutment connections before and after cyclic load application: an in vitro study. *Int. J. Oral Maxillofac. Implants* 32, 822–829.
- Gehrke, S.A., Poncio da Silva, P.M., Calvo Guirado, J.L., Delgado-Ruiz, R.A., Dedavid, B. A., Aline Nagasawa, M., Shibli, J.A., 2016a. Mechanical behavior of zirconia and titanium abutments before and after cyclic load application. *J. Prosthet. Dent* 116, 529–535.
- Gehrke, S.A., Shibli, J.A., Aramburú Junior, J.S., de Val, J.E., Calvo-Girardo, J.L., Dedavid, B.A., 2016b. Effects of different torque levels on the implant-abutment interface in a conical internal connection. *Braz. Oral Res.* 30, S1806–S83242016000100233.
- Gómez-Polo, M., Ortega, R., Gómez-Polo, C., Celemin, A., Del Rio Highsmith, J., 2018. Factors affecting the decision to use cemented or screw-retained fixed implant-supported prostheses: a critical review. *Int. J. Prosthodont.* (IJP) 31, 43–54.
- Gupta, S., Gupta, H., Tandan, A., 2015. Technical complications of implant-causes and management: a comprehensive review. *Natl. J. Maxillofac. Surg.* 6, 3–8.
- Huang, Y., Wang, J., 2019. Mechanism of and factors associated with the loosening of the implant abutment screw: a review. *J. Esthetic Restor. Dent.* 31, 338–345.
- International Organization for Standardization ISO, 2015. *Dentistry- Implants - Dynamic Fatigue Test for Endosseous Dental Implants.* The Organization, Geneva.
- Wittneben, J.G., Joda, T., Weber, H.P., Brägger, U., 2017. Screw retained vs. cement retained implant-supported fixed dental prosthesis. *Periodontol* 2000 73 (1), 141–151. <https://doi.org/10.1111/prd.12168>.
- Internet Access:** <https://www.sciencedirect.com/topics/medicine-and-dentistry/mastic-atory-force>. Accessed in 15/07/2020.
- Jorge, J.R., Barao, V.A., Delben, J.A., Assuncao, W.G., 2013. The role of implant/abutment system on torque maintenance of retention screws and vertical misfit of implant-supported crowns before and after mechanical cycling. *Int. J. Oral Maxillofac. Implants* 28, 415–422.
- Jorgensen, K.D., 1955. The relationship between retention and convergence angle in cemented veneer crowns. *Acta Odontol. Scand.* 13, 35–40.
- Kano, S.C., Binon, P.P., Curtis, D.A., 2007. A classification system to measure the implant-abutment microgap. *Int. J. Oral Maxillofac. Implants* 22, 879–885.
- Kitagawa, T., Tanimoto, Y., Odaki, M., Nemoto, K., Aida, M., 2005. Influence of implant/abutment joint designs on abutment screw loosening in a dental implant system. *J. Biomed. Mater. Res. B Appl. Biomater.* 75, 457–463.
- Lövgren, N., Roxner, R., Klemenz, S., Larsson, C., 2017. Effect of production method on surface roughness, marginal and internal fit, and retention of cobalt-chromium single crowns. *J. Prosthet. Dent* 118, 95–101.
- Mehl, C., Harder, S., Steiner, M., Vollrath, O., Kern, M., 2013. Influence of cement film thickness on the retention of implant-retained crowns. *J. Prosthodont.* 22, 618–625.
- Moraschini, V., Poubel, L.A., Ferreira, V.F., Barboza Edos, S., 2015. Evaluation of survival and success rates of dental implants reported in longitudinal studies with a follow-up period of at least 10 years: a systematic review. *Int. J. Oral Maxillofac. Surg.* 44, 377–388.
- Moris, I.C.M., Faria, A.C.L., Ribeiro, R.F., Rodrigues, R.C.S., 2015. Torque loss of different abutment sizes before and after cyclic loading. *Int. J. Oral Maxillofac. Implants* 30, 1256–1261.
- Moris, I.C.M., Faria, A.C.L., Ribeiro, R.F., Rodrigues, R.C.S., 2017. Abutments with reduced diameter for both cement and screw retentions: analysis of failure modes and misfit of abutment-crown-connections after cyclic loading. *Clin. Oral Implants Res.* 28, 432–436.
- Ozdiler, A., Bakir-Topcuoglu, N., Kulekci, G., Isik-Ozkol, G., 2018. Effects of taper angle and sealant agents on bacterial leakage along the implant-abutment interface: an in vitro study under loaded conditions. *Int. J. Oral Maxillofac. Implants* 33, 1071–1077.
- Ribeiro, C.G., Maia, M.L., Scherrer, S.S., Cardoso, A.C., Wiskott, H.W., 2011. Resistance of three implant-abutment interfaces to fatigue testing. *J. Appl. Oral Sci.* 19, 413–420.
- Safari, S., Hosseini Ghavam, F., Amini, P., Yaghmaei, K., 2018. Effects of abutment diameter, luting agent type, and re-cementation on the retention of implant-supported CAD/CAM metal copings over short abutments. *J. Adv. Prosthodont.* 10, 1–7.
- Saleh Saber, F., Abolfazli, N., Nuroloyuni, S., Khodabakhsh, S., Bahrami, M., Nahidi, R., Zeighami, S., 2012. Effect of abutment height on retention of single cement-retained, wide- and narrow-platform implant-supported restorations. *J. Dent. Res. Dent. Clin. Dent. Prospects* 6, 98–102.
- Sameera, Y., Rai, R., 2020. Tightening torque of implant abutment using hand drivers against torque wrench and its effect on the internal surface of implant. *J. Indian Prosthodont. Soc.* 20, 180–185.
- Scarano, A., Perrotti, V., Piattelli, A., Iaculli, F., Iezzi, G., 2015. Sealing capability of implant-abutment junction under cyclic loading: a toluidine blue in vitro study. *J. Appl. Biomater. Funct. Mater.* 16, e293–295.
- Scarano, A., Valbonetti, L., Degidi, M., Pecci, R., Piattelli, A., de Oliveira, P.S., Perrotti, V., 2016. Implant-abutment contact surfaces and microgap measurements of different implant connections under 3-dimensional X-ray microtomography. *Implant Dent.* 25, 656–662.
- Schiess, C., Schaefer, L., Winter, C., Fuerst, J., Rosentritt, M., Zeman, F., Behr, M., 2013. Factors determining the retentiveness of luting agents used with metal- and ceramic-based implant components. *Clin. Oral Invest.* 17, 1179–1190.
- Schmitt, C.M., Nogueira-Filho, G., Tenenbaum, H.C., Lai, J.Y., Brito, C., Döring, H., Nonhoff, J., 2014. Performance of conical abutment (Morse Taper) connection implants: a systematic review. *J. Biomed. Mater. Res. A.* 102, 552–574.
- Schoenbaum, T.R., Chang, Y.Y., Stevenson, R.G., 2018. Screw access mark for cemented implant crowns: a universal technique to simplify retrievability. *J. Oral Implantol.* 44, 71–73.
- Shadid, R., Sadaqa, N., 2012. A comparison between screw- and cement-retained implant prostheses. A literature review. *J. Oral Implantol.* 38, 298–307.
- Tan, K.M., Masri, R., Driscoll, C.F., Limkangwalmongkol, P., Romberg, E., 2012. Effect of axial wall modification on the retention of cement-retained, implant-supported crowns. *J. Prosthet. Dent* 107, 80–85.